

Radio remote V.5



Set of Equipment supplied

- 1 receiver with mini-stereo-jack 3.5 mm/12 V or 3-pin-XLR-plug
- 1 mini-stereo-jack cable (only delivered with receiver with mini-stereo-jack)
- 1 radio transmitter

Please check whether all the products you ordered are supplied.

Content

1. Introduction	4
2. The Transmitter	
2.1 Operation	5
2.3 Replacing the battery	6
3. The Receiver	
3.1 Operation	7
4. Configuring the Radio Remote	
4.1 Pairing a new transmitter and receiver	8
4.2 Activating the transmitter buttons	9
4.3 Un-Pairing a transmitter and receiver	10
4.4 Changing the frequency	12
4.5 Wiring of the connectors	12
5. System range	13
6. Technical Data	14
7. Warranty Conditions	15

1. Introduction

The UHF radio system consists of a radio transmitter and one or several receivers.

The operating frequency of the system is 433.62 MHz (freq. 1) or 434.22 MHz (freq. 2). The operating frequency is selected by putting the Jumper into the right position. The radio remote is supplied with freq. 1 as operating frequency.

The machine will be triggered to run as long as the button is held down. If the button is released, the machine will stop working.

The radio transmitter allows you to address four channels which can either be four individual receivers or four receiving groups. The number of the receivers per channel is not limited.

The transmitter is supplied with the first button pre-programmed, allowing the radio remote to be used immediately.

2. The Transmitter

Transmitter front view

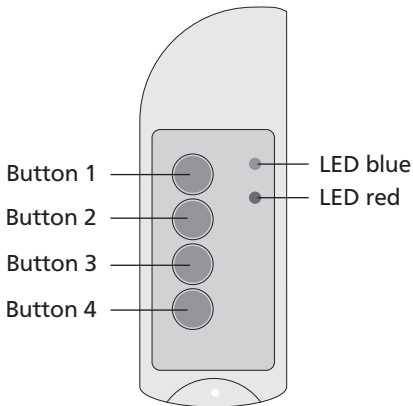

Transmitter back view

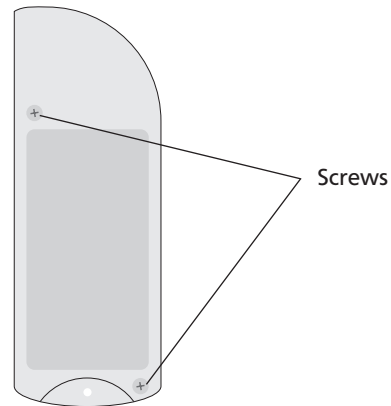

2.1 Operation

The radio transmitter is supplied in a usable state with the battery already installed.

To transmit press one of the four buttons (1, 2, 3 or 4). If the key is pressed too briefly, the receiver ignores the command.

The radio remote is supplied with the first button pre-programmed and the connected machine will be activated by pressing this button, running as long as the button is held down. Buttons two to four have no function yet.

While sending the signal, the transmitter should be in your hand and pointed away from your body. If your hand covers the integrated antenna, or you approach a large metal surface/area, the range may be reduced. This should therefore be avoided.

If a new/second transmitter should be used with the receiver, it has to be paired with the receiver (see chapter 4). The configuring and deleting of the pairing will also be described in chapter 4.

Please note: Always keep a distance of minimum 20 cm between the transmitter and receiver. Otherwise you may get error messages or the receiver will not work correctly.

2. The Transmitter

The following signals will be shown at the transmitter:

- Accurate radio signal:

Blue and red LED will flash.

- Fogging process started:

Both LEDs flashes (confirmation of a correct radio signal). After 4 to 5 times the red LED stops flashing while the blue LED continues flashing as long as the button is held down.

- Button used which is not configured (Buttons 2 to 4 at delivery):

Blue LED flashes shortly.

- No radio signal or transmitter too close to the receiver:

Blue LED flashes for a longer period very quickly.

2.3 Replacing the battery

The life of the battery depends on the use of the radio transmitter. If the range is strongly reduced or transmission is not possible, the battery must be replaced. Only use standard 12 V-alkaline batteries.

Loosen the screw with a suitable screwdriver and dismantle the two halves of the casing. Remove the depleted battery and insert the new one. Pay attention to polarity and test contact of the battery by trying to transmit.

3. The Receiver

3.1 Operation

The receiver is equipped with a mini-stereo-jack 3.5 mm [1] or a 3-pin-XLR-plug (it depends on which machine it controls) and an antenna [2].

Insert the plug [1] into the corresponding socket of the machine (or connect the receiver to the machine by using the delivered mini-stereo-jack cable) to gain control.

The receiver now gets the necessary power from the machine and is ready for operation.

Pressing of button 1 of the radio transmitter now starts the fogging process.

Please note: The antenna should be in upright position and should not be concealed by conductive objects.

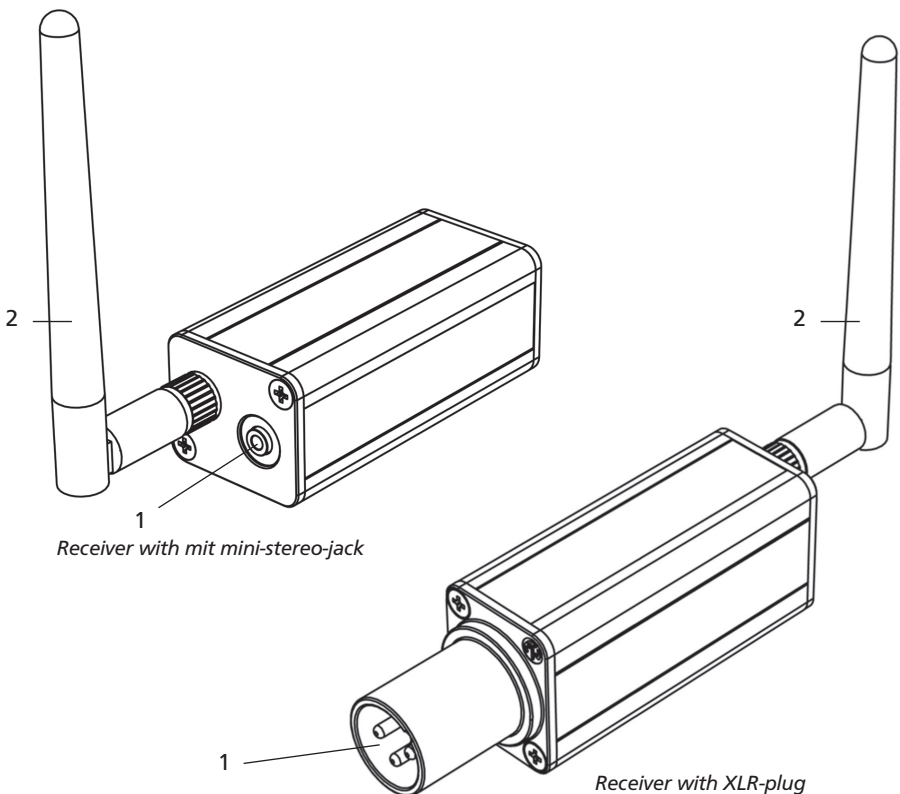

4. Configuring the Radio Remote

4.1 Pairing a new transmitter and receiver

The transmitter is supplied already paired with the receiver. If you wish to control the receiver with a second transmitter, the second transmitter must be paired with it as well.

- Open the receiver by removing the two screws on the side where the antenna is installed. Pull the PCB out of the housing.
- Connect the receiver to the machine.
- To start the pairing process, press the black Configuration button [1] briefly. The yellow LED [2] will light. Now press any button on the transmitter for one second. If the pairing is successful, the blue LED at the transmitter will flash shortly. The pairing is now complete. The receiver will respond to the transmitter.

Please note: Always keep a distance of minimum 20 cm between the transmitter and receiver. Otherwise you may get error messages or the receiver will not work correctly.

[1] black Configuration-button

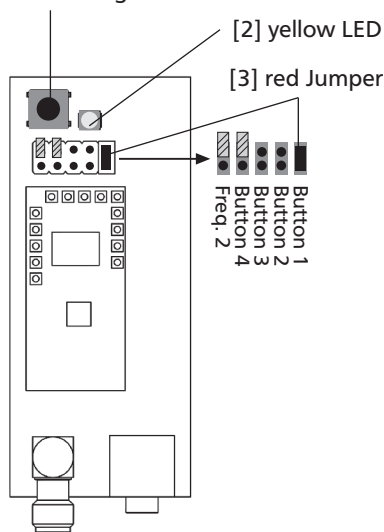

Fig. 1: Button 1 activated, Jumpers on Button 4 and Freq. 2 inactive (stored).

[1] black Configuration-button

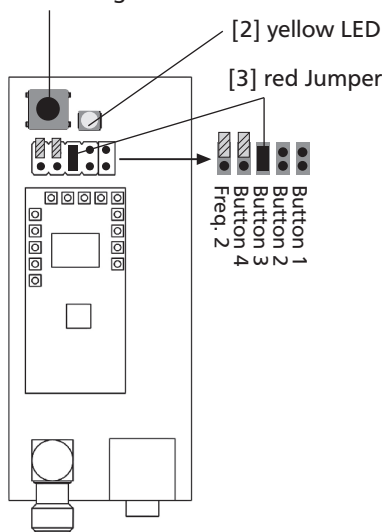

Fig. 2: Button 3 activated, Jumpers on Button 4 and Freq. 2 inactive (stored).

4. Configuring the Radio Remote

4.2 Activating the transmitter buttons

The machine connected to the receiver will be operated by pressing an activated button on a paired transmitter, creating fog as long as the button is held down.

Activate transmitter buttons by using jumpers [3] inside the receiver. The receiver is delivered with one jumper active in position 1 and 2 jumpers in an inactive (stored) position.

Figure 1 shows a receiver with jumper active in „Button 1“, and in storage (inactive) position on „Button 4“ and „Freq. 2“. This receiver will respond to Button 1 on any transmitter that has paired with it.

Figure 2 shows a receiver with jumper active on „Button 3“, and in storage (inactive) position on „Button 4“ and „Freq. 2“. This receiver will respond to transmitter Button 3.

To place or move jumpers [3]:

- a) Open the receiver by removing the two screws on the side where the antenna is installed. Pull the PCB out of the housing.
- b) Connect the receiver to the machine.
- c) To activate a button, place the jumper so that it covers both pins. If there is no jumper, or a jumper on one pin only, then that button is not active.
You can have several buttons active simultaneously. For example, if you place four jumpers in the active position for all four buttons, then any button on the transmitter will activate that receiver.

Figure 3 (see next page) shows a receiver that will respond to either button 2 and 4.

You can activate several receivers on the same button, and then all receivers will be operated when the button is held down, simultaneously and for the same duration, provided of course that all receivers have previously been paired with that transmitter.

If you wish the receivers to be operated independently rather than simultaneously, then activate a different button on each receiver.

Please note that moving jumpers to activate or de-activate buttons does not require re-pairing of the transmitter and receiver.

4. Configuring the Radio Remote

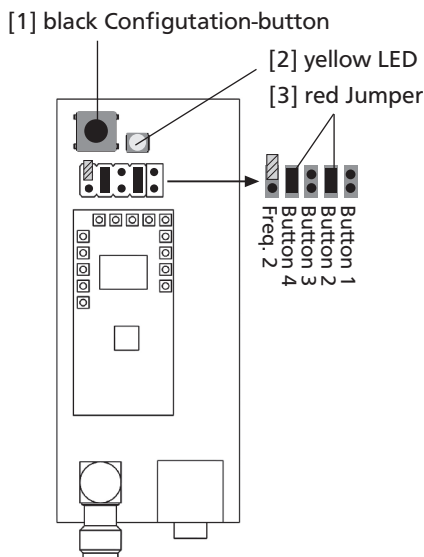

Fig. 3: Button 2 and 4 activated, Jumper on Freq. 2 inactive (stored).

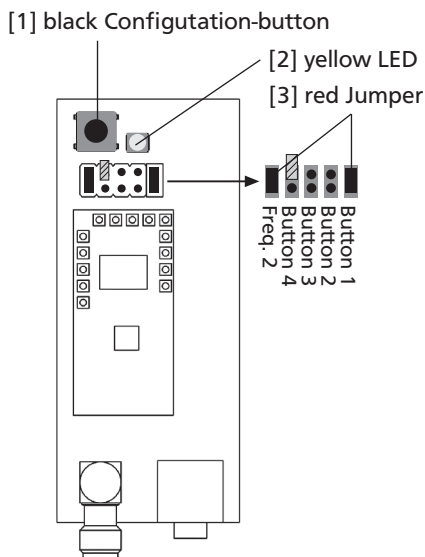

Fig. 4: Frequency 2 selected and Button 1 activated, Jumper on Button 4 inactive (stored).

4.3 Un-Pairing a transmitter and receiver

It's important to note that the receiver can be paired with several transmitters, and a transmitter can be paired with several receivers at the same time. Pairing a transmitter/receiver does not replace previous pairings; rather it adds the new pairing to the existing list.

If you want a receiver to respond to one transmitter only, then you must clear all existing pairings first, before creating the new pair. If you don't do this your receiver will continue to respond to the transmitter you used before, in addition to the new one.

4. Configuring the Radio Remote

Please note: There are two versions of the PCB for the Radio remote V5 (see Figure 5 and 6). The Un-Pairing differs for the versions like described in the following.

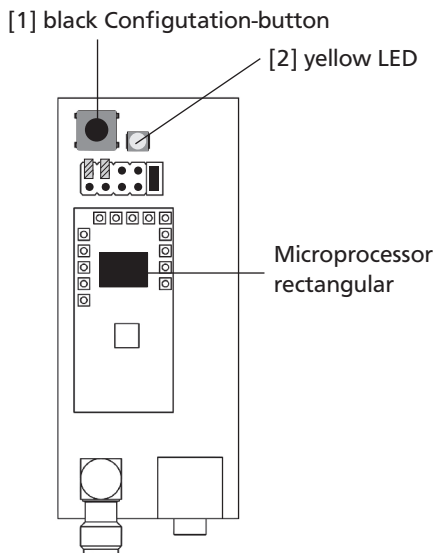

Fig. 5: PCB version 1 - Microprocessor rectangular, fixation above/below.

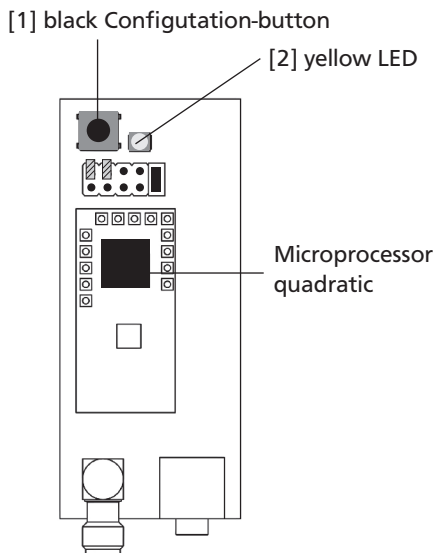

Fig. 6: PCB version 2 - Microprocessor quadratic, fixation all around.

– PCB with rectangular Microprocessor (Fig. 5):

To completely clear all pairings, press and hold the black Configuration button [1] until the yellow LED starts flashing. Now the receiver will not respond to any transmitter.

Pair the receiver with a transmitter in order to use it (see chapter 4.1).

– PCB with quadratic Microprocessor (Fig. 6):

To completely clear all pairings, press and hold the black Configuration button [1] until the yellow LED starts flashing. Release the button shortly and press it again - while the LED is still flashing - until the LED stops flashing. Now the receiver will not respond to any transmitter.

Pair the receiver with a transmitter in order to use it (see chapter 4.1).

4. Configuring the Radio Remote

4.4 Changing the frequency

The transmitter can be used on two working frequencies, which can be changed at any time. If the preset frequency (433.62 MHz) should be overused, it is possible to change to the second frequency (434.22 MHz).

To use the second frequency, you must change both the transmitter and the receiver.

- a) Open the transmitter by unscrewing the two screws on the back.
- b) Remove the protection foil of the black module.
- c) Move the white switch to position „f2“.
- d) With the receiver not connected to a machine (not receiving power), open it and set a jumper over both pins on „Freq. 2“. Thus activating that position. *Figure 4* shows a receiver that is set on the second frequency.

Now you can connect the receiver to a machine and pair it with any transmit-

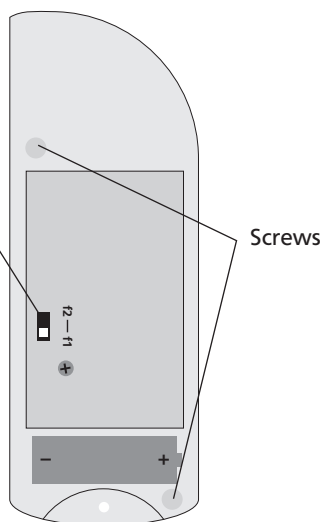

ter that has its internal white switch in position „f2“. See section 4.2 for pairing instructions.

Please note: Always keep a distance of minimum 20 cm between the transmitter and receiver. Otherwise you may get error messages or the receiver will not work correctly.

4.5 Wiring of the connectors

3-pin XLR male

Pin 1 = Ground

Pin 2 = 0 - 10 V DC (+)

Pin 3 = 12 V DC (+) input

Mini-Stereo jack

Sleeve = Ground

Ring = switch o/p

Tip = 12 V DC (+) input

5. System Range

The radio remote control is designed for a long range of 100 meters if conditions are ideal. The manual transmitter even passes through walls or reinforced concrete constructions. The maximum range is achieved only in case of visual contact with the receiver and with no radio-frequency interference.

Possible causes for reduced range:

- Building/Construction of any kind or vegetation affect the range.
- The distance of the transmitter to the body as well as the distance of the receiver to other conducting areas or objects (the soil included) affects strongly the radiation characteristic and thus influences the range.
- The antenna of the receiver should be placed upright and be vertical from the control unit.
- An antenna extension lead always causes an insertion loss and consequently reduces the received power.
- Radio noise in metropolitan areas can be relatively high, through which the signal-to-noise becomes reduced and thus the range is limited. If another unit using the same frequency is in operation near by, the radio receiver will not work or it will not receive the correct code.
- When the receiver is operated near poorly-shielded personal computers (and with most personal computers this is the case) or similar units which produce radio interference, significant range reductions can also occur or even result in the total disturbance of the receiver.
- No adjustments should be carried out to the transmitter or the receiver.

6. Technical Data

Transmitter

Working frequency 1	433.62 MHz
Working frequency 2	434.22 MHz
Coding	preset
Voltage supply	12 V DC (battery)
Power input	typ. 6 mA regularly
Working temperature	0° C to +65° C
Dimensions (L x W x H)	10 x 3.7 x 1.9 cm

Receiver

Receiving frequency	433.62 MHz and 434.22 MHz
Responsivity	1 μ V
Demodulation	log. AM-demodulator
Voltage supply	12 V DC via stereo jack plug or XLR-plug
Dimensions (L x W x H)	
Mini-stereo-jack	10.0 x 3.1 x 9.5 cm
XLR-plug	12.5 x 3.1 x 9.5 cm

Manufactured for:

Look Solutions - Fog machines made in Germany · Bünteweg 33 · DE - 30989 Gehrden

7. Warranty conditions

For the Radio remote Look Solutions guarantee is:

1. Free of charge, subject to the following conditions (No. 2 - 6) we will repair any defect or fault in the unit if it is caused by a proven factory fault and has been advised immediately after appearance and within 24 month of delivery to the end user. Insignificant deviations of the regular production quality does not guarantee replacement rights, nor do faults or defects caused by water, by generally abnormal environment conditions or Force Majeure.
2. Guarantee Service will be done in the following way: Faulty parts will be repaired or replaced (our choice) with correct parts. Faulty units have to be brought to us or our service centres or to be sent to us or our service centres at customer's expenses. The invoice and/or receipt showing the purchase date and the serial number has to come with the faulty unit, otherwise this will not be guarantee service. Replaced parts become our property.
3. The customer loses all rights for guarantee services, if any repairs or adjustments are done to the units by unauthorized persons and/or if spare parts are used which are not approved by us. Also non compliance with the instructions in this manual or mistakes by incorrect handling/ treating of the machine will lead to a loss of guarantee and also any faults and damages caused by undue force.
4. Any freight costs arising in connection with the guarantee services have to be born by the customer.
5. Guarantee services do not cause an extension of the guarantee time or the start of a new guarantee time. The warranty for replaced parts ends with the guarantee time of the whole unit.
6. If a defect/fault can not be repaired by us in a satisfactory time, we will, within 6 months after sale of the unit, on choice of the customer, either:
 - replace the whole unit for free or
 - refund the lesser value or
 - take back the whole unit and refund the purchase price, but not more than the usual market price at the time of the refund.
7. Further claims, especially for damages, losses etc. outside the unit are excluded.

Other guarantee regulations may be valid outside Germany. Please check with your dealer!

