

# **NEW**

# **LED Strobe 1320 RGBW**

---

---

**LED STROBE LIGHT**

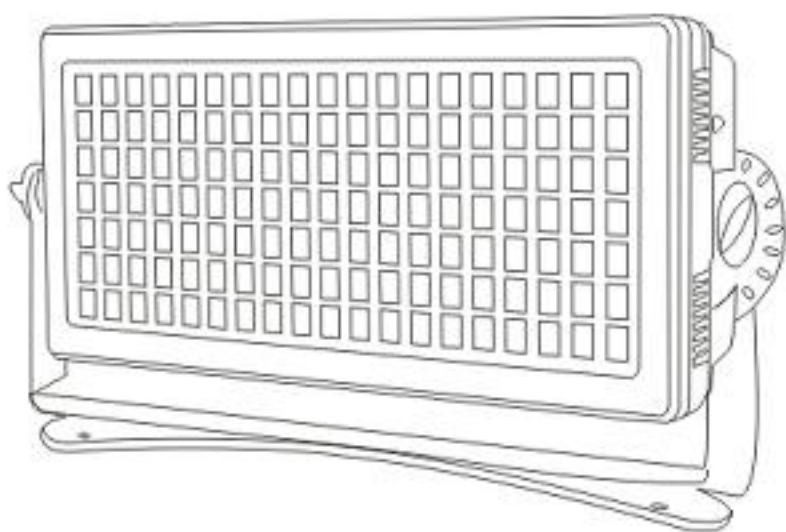

**CE**

**USER MANUAL**

## TABLE OF CONTENTS

<b>Safety information</b> .....	<b>02</b>
<b>Before using the product for the first time</b> .....	<b>03</b>
<b>Physical installation</b> .....	<b>03</b>
<b>Control menus</b> .....	<b>03</b>
<b>Menu description</b> .....	<b>04</b>
<b>DMX channel modes</b> .....	<b>05-07</b>
<b>Maintenance</b> .....	<b>07-08</b>
<b>Troubleshooting</b> .....	<b>09</b>
<b>Technical specification</b> .....	<b>10</b>
<b>Protection to fix card</b> .....	<b>11</b>

## **SAFETY INFORMATION**

### **To guard against electric shock**

- Disconnect the fixture from AC power and allow the flash capacitor to discharge for 1 minute before changing the lamp or fuse, and when not in use.
- Do not remove the rear cover: there are no user-serviceable parts inside.
- Always ground (earth) the fixture electrically.
- Use only a source of AC power that complies with local building and electrical codes and has both overload and ground-fault protection.
- Do not expose the fixture to rain or moisture.
- Replace the lamp only as described or have it replaced by a Strobe service technician.

### **To guard against UV radiation, burns, and fire**

- Never operate the fixture with the front glass open, missing or damaged.
- Do not stare directly into the light. Never look at an exposed lamp while it is lit.
- Replace the lamp when it becomes defective or worn out.
- When replacing the lamp, allow the fixture to cool for at least 10 minutes before opening the fixture or removing the lamp.
- Never attempt to bypass the fuse. Always replace defective fuses with ones of the specified type and rating.
- Verify that the power feed cable is rated for the current draw of all connected fixtures.
- Keep all combustible materials (for example fabric, wood)
- Do not illuminate surfaces within 1 meter (39 inches)
- Provide a minimum clearance of 0.1 meters (4 inches) around air vents.
- Never place filters or other materials over the front glass cover.
- The exterior of the fixture can reach temperatures up to 120° C(248° F).
- Allow the fixture to cool for at least 15 minutes before handling.
- Ensure that any supporting structure and/or hardware used can hold at least 10 times the weight of all the devices they support.
- If suspending from a rigging structure, fasten the fixture to a rigging clamp. Do not use safety cables as the primary means of support.
- Check that all external covers and rigging hardware are securely fastened.
- Block access below the work area and work from a stable platform whenever installing, servicing or moving the fixtures.
- Do not operate the fixture with missing or damaged covers, shields or any optical component.
- Do not modify the fixture or install other than genuine RUSH.

### Before using the product for the first time

1. Read safety information before installing, powering, operating or servicing the fixture.
2. Unpack and ensure that there is no transportation damage before using the fixture. Never attempt to operate a damaged fixture.
3. If the fixture is not going to be hard-wired to a mains supply, attach a local power plug(not supplied) to the end of the supplied power cable.
4. Before operating, ensure that the voltage and frequency of the power supply match the power requirements of the fixture.(See specifications on the last.)

### Physical installation

The fixture is designed for indoor use only and must be used in a dry location with adequate ventilation. Always ensure that none of the fixtures ventilation slots are blocked and always ensure that the product is firmly affixed to avoid vibration during operation.

The fixture can be oriented at any angle. Ensure that the mounting surfaces and hardware can support at least 10 times the weight of all fixtures and equipment to be installed on them.

### Control Menus

The main function are shown below

Menu	Address	Up	0-512
		Down	512-0
	Channel	4A/4B/6/10/18	
	Mouitor	CH1-CH18	
	Auto	Auto 00-Auto 36	
	Efleet On Auto	Dimmer	Value 0-225
		Strobe	Speed 0-225
	MAS mode	No	
		Yes	Slave
			Master
	Back•L	60S/120S/300S	
	Temp	Temp1	
		Temp2	
	Info	Test1	
		Test2	
		Reset	
Version			
Dimmer curve	Curve 0-3		
Dimmer control	Speed 0-7		

## Menu Description

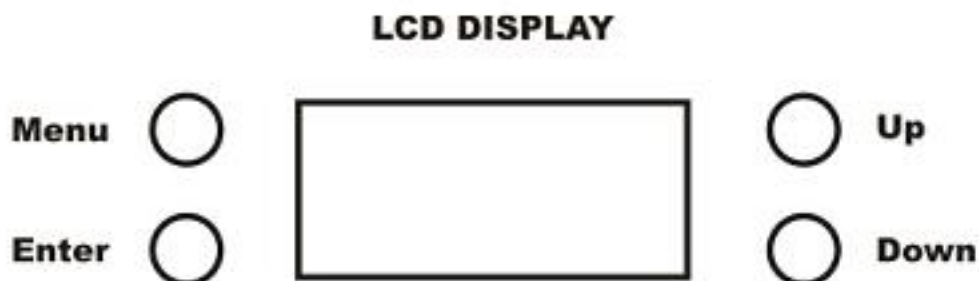

When you press the "Model" button, it will give you some information to choose.

**DMX ADD.:** Set DMX address

Push the UP or DOWN to choose the DMX Address from 001-512, or 512-001, and push ENTER to confirm.

This function is used to set or adjust the fixture's starting DMX address. Every device controlled by DMX has to have a unique starting address.

The addressing feature is what allows DMX to function properly.

The DMX address of a fixture is what allows it to communicate with a controller properly.

**Channel:** Choose the different channels

This function allows you to choose the DMX Channel, there are 5 DMX Channels: 4A DMX Channel, 4B DMX Channel, 6 DMX Channel, 10DMX Channel and 18CH, the UP or DOWN button to choose the mode, and push ENTER to confirm.

**Auto Run.**

You can choose different Auto-run Model from 00 to 20, each number has represented one effect, when you have made a choice of one, press the ENTER button to choose its speed, push the UP or DOWN button to lift the speed of strobe running.

PS: This mode is on the condition of Auto-run Mode.

The sensitivity adjustment of the strobe could be from 001-255, push the UP or DOWN to add the level of sensitivity to the device.

**PS: 001 is the highest one, on the opposite, 255 is the lowest.**

**Strobe:**

It can work as a strobe in stead of natural light, flash rate can be from 1-25 times per second.

**LED Temp.**

It allows to display some details about the functionality of the card/cards and LEDs:

**Current** : Instantly detected operating temperature

**Maximum** : Maximum detected temperature

**Minimum** : Minimum detected temperature

**Temperature Control :**

When the surface temperature of strobe is higher than 75°C, it will gradually become darker than before, the lightness could be no more than 20% full lighting.

**DMX CHANNEL:**

**4 DMX Channel :**

Channel	DMX Value	Description
Channel 1	0 ~ 4	X
	5 ~ 255	Red
Channel 2	0 ~ 4	X
	5 ~ 255	Green
Channel 3	0 ~ 4	X
	5 ~ 255	Blue
Channel 4	0 ~ 4	X
	5 ~ 255	White

**5 DMX Channel :**

Channel	DMX Value	Description
Channel 1	0 ~ 4	X
	5 ~ 255	Flash
Channel 2	0 ~ 5	X
	6 ~ 250	Flash
	250~255	RED

<b>Channel 3</b>	0 ~ 5	X
	6 ~ 250	Flash
	250~255	Green
<b>Channel 4</b>	0 ~ 5	X
	6 ~ 250	Flash
	250~255	Blue
<b>Channel 5</b>	0 ~ 5	X
	6 ~ 250	Flash
	250~255	White

#### 7 DMX Channel :

<b>Channel</b>	<b>DMX Value</b>	<b>Description</b>
Channel 1	001~255	Dimmer
Channel 2	001~255	Intensity of Flash
Channel 3	001~255	Flash
Channel 4	001~255	Random strobe
Channel 5	001~255	Special effect
Channel 6	001~255	Speed of effect
Channel 7	001~255	Special effect

#### 13 DMX Channel :

<b>Channel</b>	<b>DMX Value</b>	<b>Description</b>
Channel 1	001~255	Dimmer
Channel 2	001~255	Red
Channel 3	001~255	Green
Channel 4	001~255	Blue
Channel 5	001~255	White
Channel 6	001~255	Intensity of Flash
Channel 7	001~255	Special effect
Channel 8	001~255	Speed of effect
Channel 9	001~255	Speed of effect
Channel 10	001~255	Red
Channel 11	001~255	Green
Channel 12	001~255	Blue
Channel 13	001~255	White

**15 DMX Channel:**

<b>Channel</b>	<b>DMX Value</b>	<b>Description</b>
Channel 1	001~255	Dimmer
Channel 2	001~255	Red
Channel 3	001~255	Green
Channel 4	001~255	Blue
Channel 5	001~255	White
Channel 6	001~255	Intensity of Flash
Channel 7	001~255	Flash
Channel 8	001~255	Random strobe
Channel 9	001~255	Special effect
Channel 10	001~255	Speed of effect
Channel 11	001~255	Intensity
Channel 12	001~255	Red
Channel 13	001~255	Green
Channel 14	001~255	Blue
Channel 15	001~255	White

**31 DMX Channel:**

<b>Channel</b>	<b>DMX Value</b>	<b>Description</b>
Channel 1	0 ~ 255	Dimmer
Channel 2	0 ~ 255	Red 1
Channel 3	0 ~ 255	Green 1
Channel 4	0 ~ 255	Blue 1
Channel 5	0 ~ 255	White 1
Channel 6	0 ~ 255	Red 2
Channel 7	0 ~ 255	Green 2
Channel 8	0 ~ 255	Blue 2
Channel 9	0 ~ 255	White 2
Channel 10	0 ~ 255	Red 3
Channel 11	0 ~ 255	Green 3
Channel 12	0 ~ 255	Blue 3
Channel 13	0 ~ 255	White 3
Channel 14	0 ~ 255	Red 4



Channel 15	001~255	Green 4
Channel 16	001~255	Blue 4
Channel 17	001~255	White 4
Channel 18	001~255	Red 5
Channel 19	001~255	Green 5
Channel 20	001~255	Blue 5
Channel 21	001~255	White 5
Channel 22	001~255	Red 6
Channel 23	001~255	Green 6
Channel 24	001~255	Blue 6
Channel 25	001~255	White 6
Channel 26	001~255	Intensity of Flash
Channel 27	001~255	Flash
Channel 28	001~255	Random strobe
Channel 29	001~255	Special effect
Channel 30	001~255	Speed of effect
Channel 31	001~255	Intensity

## CLEANING AND MAINTENANCE

The following points have to be considered during the inspection:

1. All screws for installing the devices or parts of the device have to be tightly connected and must not be corroded.
2. There must not be any deformations on the housing, color lenses, fixations and installation spots (ceiling, suspension, trussing).
3. Mechanically moved parts must not show any traces of wearing and must not rotate with unbalances.



### CAUTION!

Disconnect from mains before starting maintenance operation.

**Remedies :** Check that the fixture DMX LED is on, and if not, check all DMX cables and connections to ensure the integrity of the physical network. In order to make the lights in good condition and extend the life time, we suggest a regular cleaning to the lights.

- 1) Clean the inside and outside lens each week to avoid the weakness of the lights due to accumulation of dust.
- 2) Clean the fan each week.

- 3) A detailed electric check by approved electrical engineer each three month, make sure that the circuit contacts are in good condition, prevent the poor contact of circuit from overheating
- 4) The cleaning of external optical lenses must be carried out periodically to optimize light output. Cleaning schedules for lighting fixtures vary greatly depending on the operating environment.
- 5) It is therefore impossible to specify precise cleaning intervals for the fixture, environmental factors that may result in a need for frequent cleaning include :
  - A : Use of smoke or fog machines.
  - B : High airflow rates ( near air conditioning vents, for example. )
  - C : Presence of cigarette smoke.
  - D : Airborne dust(from stage effects, building structures and fittings or the natural environment at outdoor events, for example.
- 6) Use gentle pressure only when cleaning, and work in a clean, well-lit area. Do not use any product that contains solvents or abrasives, as these can cause surface damage.

#### **Troubleshooting :**

**This section describes a few common problems that may occur during operation and provides some suggestions for easy troubleshooting.**

##### **A. Lights can't work, no lights out**

1. Check power connection, the fuse whether is ok.
2. Check power input whether correct.

##### **B. Can't DMX control.**

1. DMX signal indicator must be on, if not, check the DMX cable.
2. If DMX signal is OK, check the DMX address whether set OK.
3. If DMX signal not consistent, check the DMX port connect.

##### **C. Fixture does not respond to DMX control**

**Potential cause :** Fault in the DMX net work due to connector or cable damaged, or incorrect DMX addressing, or potential interference from proximity to a high voltage installation.

## Specification:

- Voltage : AC110-240V 50/60Hz
- Lamp : 1320pcs RGBW SMD LEDs.
- Channels : **4/5/7/13/15/31 CH optional**
- Mode : DMX 512, Master/Slaver, Auto run.
- Power : 1500W DMX Strobe Light
- Packing Size : 560\*230\*320cm
- Weight : 12.5KG
- Compact Design
- DMX-512 protocol 0-100% dimming control
- DMX512 channels for speed and dimming Special Functions:

### Remark:

Errors and omissions for every information given in this manual except.  
All information is subject to change without prior notice.

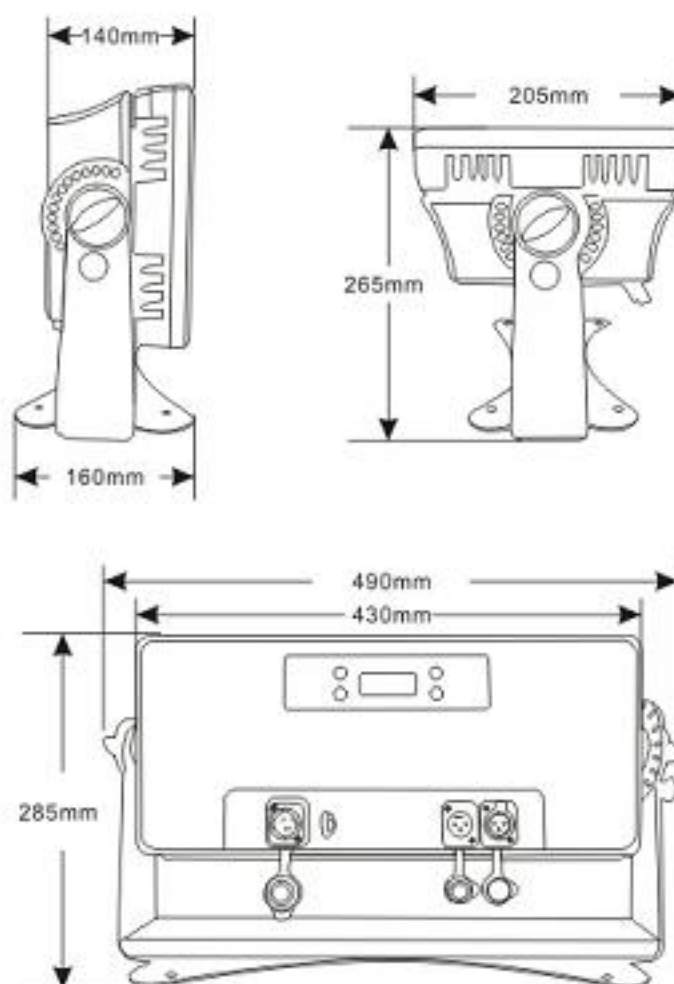

## Protection to Fix Card

Product		Type	
Serial No.			
Warranty Period			
Customer	Name:		
	Tel.:		
	ADD.:		
Distributor name		ADD.:	
	Tel.:	Postal Code:	